

A close-up photograph of a BISON VDI toolholder. The toolholder is a cylindrical metal component with a black finish and a silver-colored inner bore. It features a gold-colored BISON logo on its side. In the background, a white metal component with three circular holes and a BISON logo is visible. The scene is lit with a warm, orange light, likely from a machine tool lamp.

5

**VDI - WERKZEUGHALTER**  
**VDI - TOOLHOLDERS**

**BISON**

# VDI - WERKZEUGHALTER

## VDI - TOOLHOLDERS



### Art des Halters: Product group:



Werkzeughalter Drehmeißel  
Square Toolholders



Werkzeughalter für runde Werkzeuge  
Round Toolholders

### Form des Werkzeughalters: Toolholder form:



### Ausführung des Werkzeughalters: Toolholder direction:



rechts  
right



links  
left

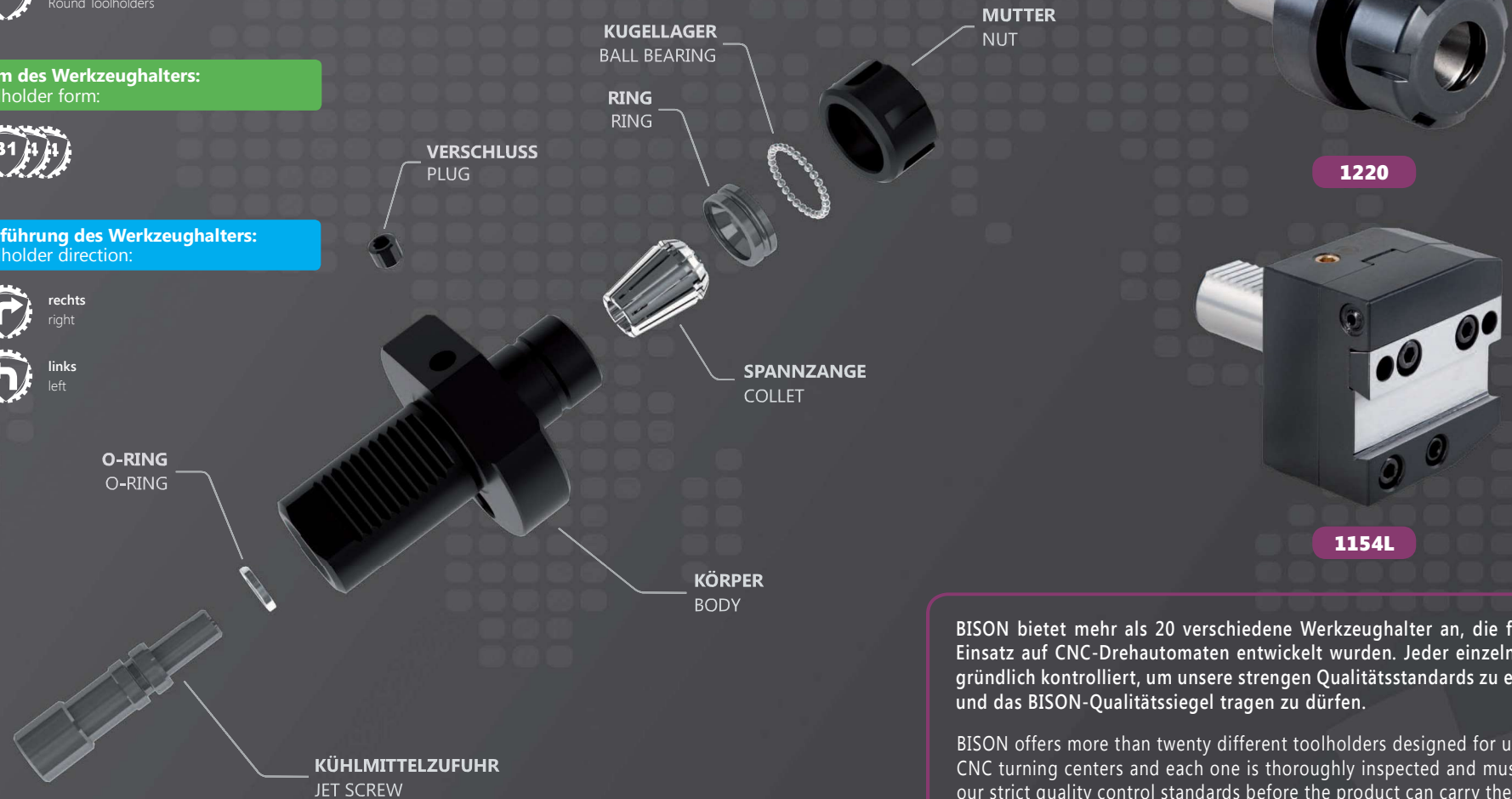

BISON bietet mehr als 20 verschiedene Werkzeughalter an, die für den Einsatz auf CNC-Drehautomaten entwickelt wurden. Jeder einzelne wird gründlich kontrolliert, um unsere strengen Qualitätsstandards zu erfüllen und das BISON-Qualitätssiegel tragen zu dürfen.

BISON offers more than twenty different toolholders designed for use with CNC turning centers and each one is thoroughly inspected and must meet our strict quality control standards before the product can carry the BISON name.



### I WERKZEUGHALTER FÜR DREHMEISSEL SQUARE TOOLHOLDERS 274-277

TYP TYPE	BESCHREIBUNG DESCRIPTION	SEITE PAGE
1114P	RADIAL WERKZEUGHALTER - B1 RADIAL TOOLHOLDERS - B1	274
1114L	RADIAL WERKZEUGHALTER - B2 RADIAL TOOLHOLDERS - B2	274
1115P	RADIAL WERKZEUGHALTER INVERS - B3 INVERTED RADIAL TOOLHOLDERS - B3	274
1115L	RADIAL WERKZEUGHALTER INVERS - B4 INVERTED RADIAL TOOLHOLDERS - B4	274
1124P	RADIAL WERKZEUGHALTER - B5 EXTENDED RADIAL TOOLHOLDERS - B5	275
1124L	RADIAL WERKZEUGHALTER - B6 EXTENDED RADIAL TOOLHOLDERS - B6	275
1125P	RADIAL WERKZEUGHALTER INVERS - B7 EXTENDED INVERTED RADIAL TOOLHOLDERS - B7	275
1125L	RADIAL WERKZEUGHALTER INVERS - B8 EXTENDED INVERTED RADIAL TOOLHOLDERS - B8	275
1133P	AXIAL WERKZEUGHALTER - C1 AXIAL TOOLHOLDERS - C1	276
1133L	AXIAL WERKZEUGHALTER - C2 AXIAL TOOLHOLDERS - C2	276
1134P	AXIAL WERKZEUGHALTER INVERS - C3 INVERTED AXIAL TOOLHOLDERS - C3	276
1134L	AXIAL WERKZEUGHALTER INVERS - C4 INVERTED AXIAL TOOLHOLDERS - C4	276
1143	KOMBINIERTER WERKZEUGHALTER - D1 COMBINED TOOLHOLDERS - D1	277
1144	KOMBINIERTER WERKZEUGHALTER INVERS - D2 COMBINED TOOLHOLDERS INVERTED - D2	277
1154P	WERKZEUGHALTER FÜR STECHWERKZEUGE TOOLHOLDERS FOR CUT-OFF TOOLS	277
1154L	WERKZEUGHALTER FÜR STECHWERKZEUGE TOOLHOLDERS FOR CUT-OFF TOOLS	277

### II WERKZEUGHALTER FÜR RUNDE WERKZEUGE ROUND TOOLHOLDERS 278-280

TYP TYPE	BESCHREIBUNG DESCRIPTION	SEITE PAGE
1220	WERKZEUGHALTER FÜR SPANNZANGEN ER (DIN 6499) - E4 TOOLHOLDERS FOR COLLETS ER (DIN 6499) - E4	278
1224	WERKZEUGHALTER FÜR BOHRSTANGEN MIT MORSEKEGEL - F1 TOOLHOLDERS FOR BORING BARS WITH MORSE TAPER - F1	278
1253	WERKZEUGHALTER FÜR WERKZEUGE MIT ZYLINDRISCHEM SCHAFT TOOLHOLDERS FOR TOOLS WITH CYLINDRICAL SHANK	278
1252P	WERKZEUGHALTER FÜR WERKZEUGE MIT ZYLINDRISCHEM SCHAFT TOOLHOLDERS FOR TOOLS WITH CYLINDRICAL SHANK	279
1252L	WERKZEUGHALTER FÜR WERKZEUGE MIT ZYLINDRISCHEM SCHAFT TOOLHOLDERS FOR TOOLS WITH CYLINDRICAL SHANK	279
1254	WERKZEUGHALTER FÜR WERKZEUGE MIT ZYLINDRISCHEM SCHAFT - E1 TOOLHOLDERS FOR TOOLS WITH CYLINDRICAL SHANK - E1	279
1258	WERKZEUGHALTER FÜR WERKZEUGE MIT ZYLINDRISCHEM SCHAFT - E2 TOOLHOLDERS FOR TOOLS WITH CYLINDRICAL SHANK - E2	280
1230	WERKZEUGHALTER FÜR BOHRSTANGEN TOOLHOLDERS FOR BORING BARS	280

### III WERKZEUGHALTER ROHLING TOOLHOLDER BLANKS 281

TYP TYPE	BESCHREIBUNG DESCRIPTION	SEITE PAGE
1201	ROHLING WERKZEUGHALTER, A1 BLANK TOOLHOLDERS, A1	281
1203	ROHLING WERKZEUGHALTER, A2 BLANK TOOLHOLDERS, A2	281

### IV ZUBEHÖR UND ERSATZTEILE SPARE PARTS & ACCESSORIES 282-284

1  
2  
3  
4  
5  
6  
1114P  
1114L  
1115P  
1115L  
274

### 1114P

- Radial Werkzeughalter
- Radial Toolholder

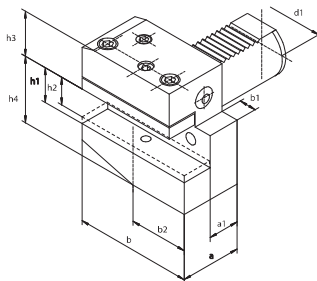

Artikel Nr. Code No.	Typ Type	DIN 69880	d1	a	a1	b	b1	b2	h1	h2	h3	h4
341114001200	1114-16P	B1-16 x 12 x 24	16	24	13	42	5,0	23,0	12	10	20,0	22
341114004000	1114-16P-L	B1-16 x 12 x 34	16	34	23	42	5,0	23,0	12	10	20,0	22
341114003800	1114-20P	B1-20 x 16 x 30	20	30	16	55	7,0	30,0	16	12	25,0	30
341114006600	1114-20P-L	B1-20 x 16 x 40	20	40	26	55	7,0	30,0	16	12	25,0	30
341114008100	1114-25P	B1-25 x 16 x 30	25	30	16	55	7,0	30,0	16	12	25,0	30
341114009400	1114-25P-L	B1-25 x 16 x 40	25	40	26	55	7,0	30,0	16	12	25,0	30
341114005300	1114-30P	B1-30 x 20 x 40	30	40	22	70	10,0	35,0	20	16	28,0	38
341114007900	1114-30P-L	B1-30 x 20 x 60	30	60	42	70	10,0	35,0	20	16	28,0	38
341114010100	1114-40P	B1-40 x 25 x 44	40	44	22	85	12,5	42,5	25	20	32,5	48
341114020300	1114-50P	B1-50 x 32 x 55	50	55	30	100	16,0	50,0	32	25	35,0	60

### 1114L

- Radial Werkzeughalter
- Radial Toolholder

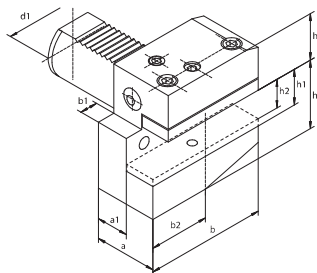

Artikel Nr. Code No.	Typ Type	DIN 69880	d1	a	a1	b	b1	b2	h1	h2	h3	h4
341114100000	1114-16L	B2-16 x 12 x 24	16	24	13	42	5,0	23,0	12	10	20,0	22
341114101300	1114-16L-L	B2-16 x 12 x 34	16	34	23	42	5,0	23,0	12	10	20,0	22
341114110200	1114-20L	B2-20 x 16 x 30	20	30	16	55	7,0	30,0	16	12	25,0	30
341114111500	1114-20L-L	B2-20 x 16 x 40	20	40	26	55	7,0	30,0	16	12	25,0	30
341114112800	1114-25L	B2-25 x 16 x 30	25	30	16	55	7,0	30,0	16	12	25,0	30
341114113000	1114-25L-L	B2-25 x 16 x 40	25	40	26	55	7,0	30,0	16	12	25,0	30
341114120400	1114-30L	B2-30 x 20 x 40	30	40	22	70	10,0	35,0	20	16	28,0	38
341114122000	1114-30L-L	B2-30 x 20 x 60	30	60	42	70	10,0	35,0	20	16	28,0	38
341114130600	1114-40L	B2-40 x 25 x 44	40	44	22	85	12,5	42,5	25	20	32,5	48
341114140800	1114-50L	B2-50 x 32 x 55	50	55	30	100	16,0	50,0	32	25	35,0	60

### 1115P

- Radial Werkzeughalter invers
- Inverted radial toolholders

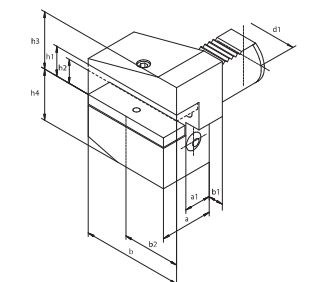

Artikel Nr. Code No.	Typ Type	DIN 69880	d1	a	a1	b	b1	b2	h1	h2	h3	h4
341115001000	1115-16P	B3-16 x 12 x 24	16	24	13	42	5,0	23,0	12	10	22	20,0
341115004900	1115-16P-L	B3-16 x 12 x 34	16	34	23	42	5,0	23,0	12	10	22	20,0
341115003600	1115-20P	B3-20 x 16 x 30	20	30	16	55	7,0	30,0	16	12	30	25,0
341115006400	1115-20P-L	B3-20 x 16 x 40	20	40	26	55	7,0	30,0	16	12	30	25,0
341115008000	1115-25P	B3-25 x 16 x 30	25	30	16	55	7,0	30,0	16	12	30	25,0
341115009200	1115-25P-L	B3-25 x 16 x 40	25	40	26	55	7,0	30,0	16	12	30	25,0
341115005100	1115-30P	B3-30 x 20 x 40	30	40	22	70	10,0	35,0	20	16	38	35,0
341115007700	1115-30P-L	B3-30 x 20 x 60	30	60	42	70	10,0	35,0	20	16	38	35,0
341115010000	1115-40P	B3-40 x 25 x 44	40	44	22	85	12,5	42,5	25	20	48	42,5
341115020100	1115-50P	B3-50 x 32 x 55	50	55	30	100	16,0	50,0	32	25	60	50,0

### 1115L

- Radial Werkzeughalter invers
- Inverted radial toolholders

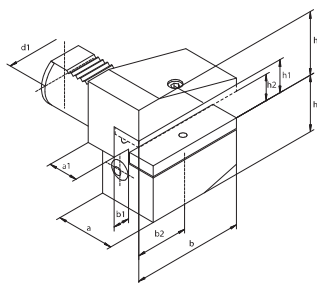

Artikel Nr. Code No.	Typ Type	DIN 69880	d1	a	a1	b	b1	b4	h1	h2	h3	h4
341115103700	1115-16L	B4-16 x 12 x 24	16	24	13	42	5,0	23,0	12	10	22	20,0
341115104000	1115-16L-L	B4-16 x 12 x 34	16	34	23	42	5,0	23,0	12	10	22	20,0
341115105200	1115-20L	B4-20 x 16 x 30	20	30	16	55	7,0	30,0	16	12	30	25,0
341115106500	1115-20L-L	B4-20 x 16 x 40	20	40	26	55	7,0	30,0	16	12	30	25,0
341115107800	1115-25L	B4-25 x 16 x 30	25	30	16	55	7,0	30,0	16	12	30	25,0
341115108000	1115-25L-L	B4-25 x 16 x 40	25	40	26	55	7,0	30,0	16	12	30	25,0
341115110000	1115-30L	B4-30 x 20 x 40	30	40	22	70	10,0	35,0	20	16	38	35,0
341115112600	1115-30L-L	B4-30 x 20 x 60	30	60	42	70	10,0	35,0	20	16	38	35,0
341115120200	1115-40L	B4-40 x 25 x 44	40	44	22	85	12,5	42,5	25	20	48	42,5
341115130400	1115-50L	B4-50 x 32 x 55	50	55	30	100	16,0	50,0	32	24	60	50,0

Artikel Nr.	Typ	DIN 69880	d1	a	a1	b	b1	b2	h1	h2	h3	h4
Code No.	Type											
341124010900	1124-16P	B5-16 x 12 x 24	16	24	13	58	5,0	39,0	12	10	20,0	22
341124011100	1124-16P-L	B5-16 x 12 x 34	16	34	23	58	5,0	39,0	12	10	20,0	22
341124020000	1124-20P	B5-20 x 16 x 30	20	30	16	75	7,0	50,0	16	12	25,0	30
341124021300	1124-20P-L	B5-20 x 16 x 40	20	40	26	75	7,0	30,0	16	12	25,0	30
341124022600	1124-25P	B5-25 x 16 x 30	25	30	16	75	7,0	50,0	16	12	25,0	30
341124023900	1124-25P-L	B5-25 x 16 x 40	25	40	26	75	7,0	50,0	16	12	25,0	30
341124030200	1124-30P	B5-30 x 20 x 40	30	40	22	100	10,0	65,0	20	16	28,0	38
341124032800	1124-30P-L	B5-30 x 20 x 60	30	60	42	100	10,0	65,0	20	16	28,0	38
341124040400	1124-40P	B5-40 x 25 x 44	40	44	22	118	12,5	75,5	25	20	32,5	48
341124050600	1124-50P	B5-50 x 32 x 55	50	55	30	130	16,0	80,0	32	25	35,0	60

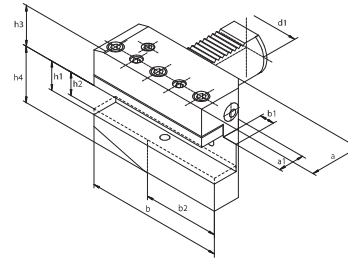

## 1124P

- Radial Werkzeughalter
- Extended radial toolholders



Artikel Nr.	Typ	DIN 69880	d1	a	a1	b	b1	b2	h1	h2	h3	h4
Code No.	Type											
341124110000	1124-16L	B6-16 x 12 x 24	16	24	13	58	5,0	39,0	12	10	20,0	22
341124111200	1124-16L-L	B6-16 x 12 x 34	16	34	23	58	5,0	39,0	12	10	20,0	22
341124120100	1124-20L	B6-20 x 16 x 30	20	30	16	75	7,0	50,0	16	12	25,0	30
341124121400	1124-20L-L	B6-20 x 16 x 40	20	40	26	75	7,0	50,0	16	12	25,0	30
341124125500	1124-25L	B6-25 x 16 x 30	25	30	16	75	7,0	50,0	16	12	25,0	30
341124126800	1124-25L-L	B6-25 x 16 x 40	25	40	26	75	7,0	50,0	16	12	25,0	30
341124130300	1124-30L	B6-30 x 20 x 40	30	40	22	100	10,0	65,0	20	16	28,0	38
341124132900	1124-30L-L	B6-30 x 20 x 60	30	60	42	100	10,0	65,0	20	16	28,0	38
341124140500	1124-40L	B6-40 x 25 x 44	40	44	22	118	12,5	75,5	25	20	32,5	48
341124150700	1124-50L	B6-50 x 32 x 55	50	55	30	130	16,0	80,0	32	25	35,0	60

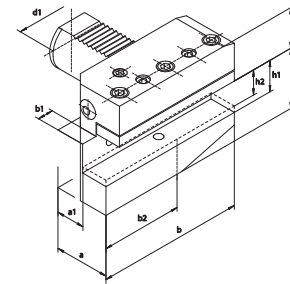

## 1124L

- Radial Werkzeughalter
- Extended radial toolholders



Artikel Nr.	Typ	DIN 69880	d1	a	a1	b	b1	b2	h1	h2	h3	h4
Code No.	Type											
341125010700	1125-16P	B7-16 x 12 x 24	16	24	13	58	5,0	39,0	12	10	22	20,0
341125011000	1125-16P-L	B7-16 x 12 x 34	16	34	23	58	5,0	39,0	12	10	22	20,0
341125020900	1125-20P	B7-20 x 16 x 30	20	30	16	75	7,0	50,0	16	12	30	25,0
341125021100	1125-20P-L	B7-20 x 16 x 40	20	40	26	75	7,0	50,0	16	12	30	25,0
341125024400	1125-25P	B7-25 x 16 x 30	25	30	16	75	7,0	50,0	16	12	30	25,0
341125023700	1125-25P-L	B7-25 x 16 x 40	25	40	26	75	7,0	50,0	16	12	30	25,0
341125030000	1125-30P	B7-30 x 20 x 40	30	40	22	100	10,0	65,0	20	16	38	35,0
341125032600	1125-30P-L	B7-30 x 20 x 60	30	60	42	100	10,0	65,0	20	16	38	35,0
341125040200	1125-40P	B7-40 x 25 x 44	40	44	22	118	12,5	75,5	25	20	48	42,5
341125050400	1125-50P	B7-50 x 32 x 55	50	55	30	130	16,0	80,0	32	25	60	50,0

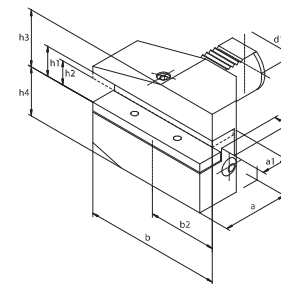

## 1125P

- Radial Werkzeughalter invers
- Extended inverted radial toolholders



Artikel Nr.	Typ	DIN 69880	d1	a	a1	b	b1	b2	h1	h2	h3	h4
Code No.	Type											
341125110800	1125-16L	B8-16 x 12 x 24	16	24	13	58	5,0	39,0	12	10	22	20,0
341125111000	1125-16L-L	B8-16 x 12 x 34	16	34	23	58	5,0	39,0	12	10	22	20,0
341125120000	1125-20L	B8-20 x 16 x 30	20	30	16	75	7,0	50,0	16	12	30	25,0
341125121200	1125-20L-L	B8-20 x 16 x 40	20	40	26	75	7,0	50,0	16	12	30	25,0
341125122500	1125-25L	B8-25 x 16 x 30	25	30	16	75	7,0	50,0	16	12	30	25,0
341125123800	1125-25L-L	B8-25 x 16 x 40	25	40	26	75	7,0	50,0	16	12	30	25,0
341125130100	1125-30L	B8-30 x 20 x 40	30	40	22	100	10,0	65,0	20	16	38	35,0
341125132700	1125-30L-L	B8-30 x 20 x 60	30	60	42	100	10,0	65,0	20	16	38	35,0
341125140300	1125-40L	B8-40 x 25 x 44	40	44	22	118	12,5	75,5	25	20	48	42,5
341125150500	1125-50L	B8-50 x 32 x 55	50	55	30	130	16,0	80,0	32	25	60	50,0

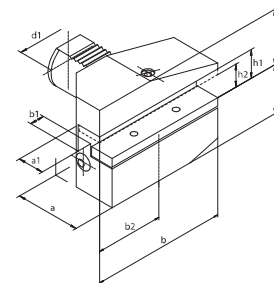

## 1125L

- Radial Werkzeughalter invers
- Extended inverted radial toolholders



1  
2  
3  
4  
5  
6  
1133P  
1133L  
1134P  
1134L

### 1133P

- Axial Werkzeughalter
- Axial Toolholder

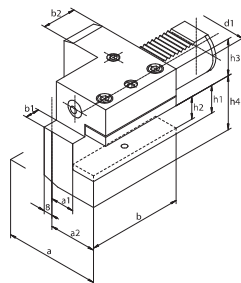

Artikel Nr. Code No.	Typ Type	DIN 69880	d1	a	a1	a2	b	b1	b2	h1	h2	h3	h4
34113300600	1133-16P	C1-16 x 12	16	43	13	24,0	44	5,0	20	12	10	20,0	22
341133002100	1133-20P	C1-20 x 16	20	52	13	27,0	55	7,0	30	16	12	25,0	30
341133003400	1133-20P-L	-	20	65	26	40,0	50	-	30	16	12	25,0	30
341133004700	1133-25P	C1-25 x 16	25	58	19	33,0	55	7,0	20	16	12	25,0	30
341133005000	1133-30P	C1-30 x 20	30	70	17	35,0	70	10,0	30	20	16	28,0	38
341133010800	1133-40P	C1-40 x 25	40	85	21	42,5	85	12,5	30	25	20	32,5	48
341133030100	1133-50P	C1-50 x 32	50	100	26	50,0	100	16,0	40	32	25	35,0	60

### 1133L

- Axial Werkzeughalter
- Axial Toolholder

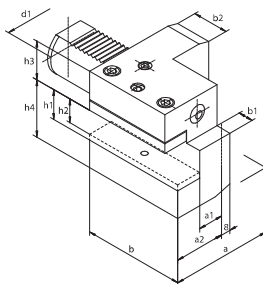

Artikel Nr. Code No.	Typ Type	DIN 69880	d1	a	a1	a2	b	b1	b2	h1	h2	h3	h4
341133110900	1133-16L	C2-16 x 12	16	43	13,0	24,0	44	5,0	20	12	10	20,0	22
341133120000	1133-20L	C2-20 x 16	20	65	26,0	40,0	50	-	30	16	12	25,0	30
341133121300	1133-25L	C2-25 x 16	25	58	19,0	33,0	55	7,0	20	16	12	25,0	30
341133130200	1133-30L	C2-30 x 20	30	76	23,0	41,0	70	10,0	30	20	16	28,0	38
341133140400	1133-40L	C2-40 x 25	40	90	25,5	47,5	85	12,5	30	25	20	32,5	48
341133150600	1133-50L	C2-50 x 32	50	105	30,5	55,0	100	16,0	40	32	25	35,0	60

### 1134P

- Axial Werkzeughalter invers
- Inverted axial toolholder

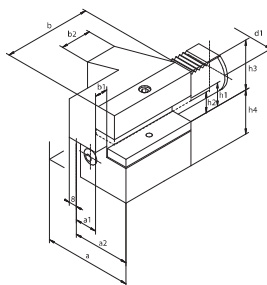

Artikel Nr. Code No.	Typ Type	DIN 69880	d1	a	a1	a2	b	b1	b2	h1	h2	h3	h4
341134010600	1134-16P	C3-16 x 12	16	43	13	24,0	44	5,0	20	12	10	22	20,0
341134020800	1134-20P	C3-20 x 16	20	52	13	27,0	55	7,0	30	16	12	30	25,0
341134021000	1134-20P-L	-	20	65	26	40,0	50	-	30	16	12	30	25,0
341134022300	1134-25P	C3-25 x 16	25	58	19	33,0	55	7,0	20	16	12	30	25,0
341134030000	1134-30P	C3-30 x 20	30	70	17	35,0	70	10,0	30	20	16	38	35,0
341134040100	1134-40P	C3-40 x 25	40	85	21	42,5	85	12,5	30	25	20	48	42,5
341134050300	1134-50P	C3-50 x 32	50	100	26	50,0	100	16,0	40	32	25	60	50,0

### 1134L

- Axial Werkzeughalter invers
- Inverted axial toolholder

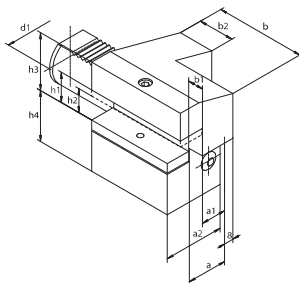

Artikel Nr. Code No.	Typ Type	DIN 69880	d1	a	a1	a2	b	b1	b2	h1	h2	h3	h4
341134110700	1134-16L	C4-16 x 12	16	43	13,0	24,0	44	5,0	20	12	10	22	20,0
341134120900	1134-20L	C4-20 x 16	20	65	26,0	40,0	50	-	30	16	12	30	25,0
341134121100	1134-25L	C4-25 x 16	25	58	19,0	33,0	55	7,0	20	16	12	25	25,0
341134130000	1134-30L	C4-30 x 20	30	76	23,0	41,0	70	10,0	30	20	16	38	35,0
341134140200	1134-40L	C4-40 x 25	40	90	25,5	47,5	85	12,5	30	25	20	48	42,5
341134150400	1134-50L	C4-50 x 32	50	105	30,5	55,0	100	16,0	40	32	25	60	50,0



**1220**



- Werkzeughalter für Spannzangen ER (DIN 6499)
- Toolholder for collets ER (DIN 6499)

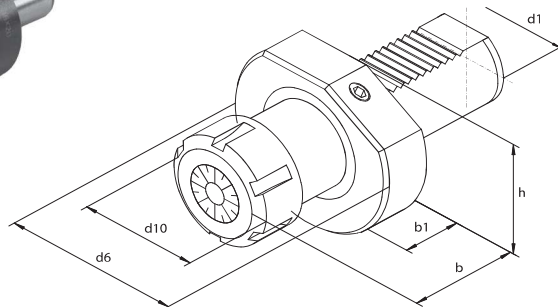

Artikel Nr.	Typ	DIN 69880	d1	d6	d10	b	b1	h	Spannzange	
									ER	Spannbereich
Code No.	Type								Collet chuck	
									ER	Clamping range
341220030600	1220-16-ER20	E4-16 x 20	16	40	35	45	14	18,0	20	2-13
341220115700	1220-20-ER16	-	20	50	32	55	18	-	16	2-10
341220120500	1220-20-ER25	E4-20 x 25	20	50	42	55	18	-	25	2-16
341220130700	1220-20-ER32	E4-20 x 32	20	50	50	55	18	-	32	2-20
341220220600	1220-25-ER25	E4-25 x 25	25	58	42	55	18	25,0	25	2-16
341220230800	1220-25-ER32	E4-25 x 32	25	58	50	55	18	25,0	32	2-20
341220312000	1220-30-ER25	E4-30 x 25	30	68	42	55	22	28,0	25	2-16
341220310500	1220-30-ER25-L	-	30	68	42	75	34	28,0	25	2-16
341220322200	1220-30-ER32	-	30	68	50	55	22	28,0	32	2-20
341220320700	1220-30-ER32-L	-	30	68	50	75	29	28,0	32	2-20
341220340000	1220-30-ER40	E4-30 x 40	30	68	63	75	26	28,0	40	3-26
341220420800	1220-40-ER25	-	40	83	42	69	22	32,5	25	2-16
341220430000	1220-40-ER32	E4-40 x 32	40	83	50	84	22	32,5	32	2-20
341220440100	1220-40-ER40	E4-40 x 40	40	83	63	75	22	32,5	40	3-26
341220500500	1220-50-ER32	-	50	98	50	84	30	35,0	32	2-20
341220510700	1220-50-ER40	E4-50 x 40	50	98	63	88	30	35,0	40	3-26

Spannzangen finden Sie auf Seite 374 ■ Collets available on page 374

**1224**



- Werkzeughalter für Werkzeuge mit Morsekegel
- Toolholder for boring bars with morse taper

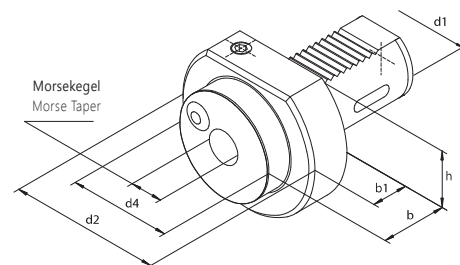

Artikel Nr.	Typ	DIN 69880	d1	Morsekegel	d2	d4	b	b1	h
341224001600	1224-20-1	F20-MK-DK1	20	1	50	-	27	-	-
341224010500	1224-30-1	F30-MK-DK1	30	1	68	68	27	-	28,0
341224020700	1224-30-2	F30-MK-DK2	30	2	68	58	36	25	28,0
341224000300	1224-30-3	-	30	3	68	68	66	-	28,0
341224030900	1224-40-2	F40-MK-DK2	40	2	83	55	36	22	32,5
341224040000	1224-40-3	F40-MK-DK3	40	3	83	58	50	22	32,5
341224050200	1224-40-4	F40-MK-DK4	40	4	83	68	80	22	32,5
341224060400	1224-50-2	F50-MK-DK2	50	2	98	55	36	30	35,0
341224070600	1224-50-3	F50-MK-DK3	50	3	98	58	45	30	35,0
341224080800	1224-50-4	F50-MK-DK4	50	4	98	68	55	30	35,0

**1253**



- Für DIN 1835B, E und ISO 3338/2 "Whistle notch"
- Werkzeughalter für Werkzeuge mit zylindrischem Schaft
- According to DIN 1835B, E and ISO 3338/2 "Whistle notch"
- Toolholder for tools with cylindrical shank

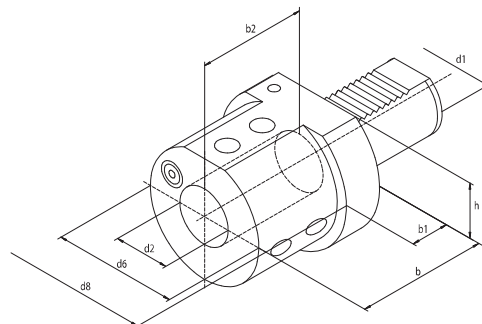

Artikel Nr.	Typ	d1	d2	d6	d8	b	b1	b2	h
341253031500	1253-40-20	40	20	52	83	67	22	54	32,5
341253032800	1253-40-25	40	25	65	83	85	22	59	32,5
341253033000	1253-40-32	40	32	72	83	85	22	63	32,5
341253034300	1253-40-40*	40	40	83	83	90	-	73	32,5

\*auf Anfrage \*on request

1220

1224

1253

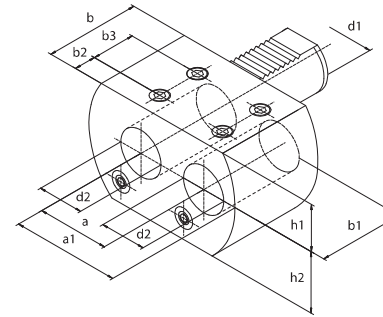

Artikel Nr.	Typ	d1	d2/H7	a	a1	b	b1	b2	b3	h1	h2
Code No.	Type										
341252020200	1252-30-25P	30	25	45	65	56	52	14	24	28,0	34,0
341252030400	1252-40-32P	40	32	50	75	66	60	15	30	32,5	42,5

**1252P**

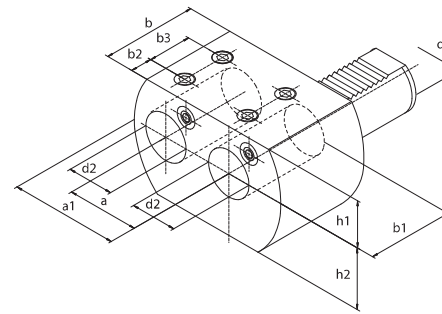

- Werkzeughalter für Werkzeuge mit zylindrischem Schaft
- Toolholder for tools with cylindrical shank - double

Artikel Nr.	Typ	d1	d2/H7	a	a1	b	b1	b2	b3	h1	h2
Code No.	Type										
341252021500	1252-30-25L	30	25	45	65	56	52	14	24	28,0	34,0
341252031700	1252-40-32L	40	32	50	75	66	60	15	30	32,5	42,5

**1252L**

- Werkzeughalter für Werkzeuge mit zylindrischem Schaft
- Toolholder for tools with cylindrical shank - double

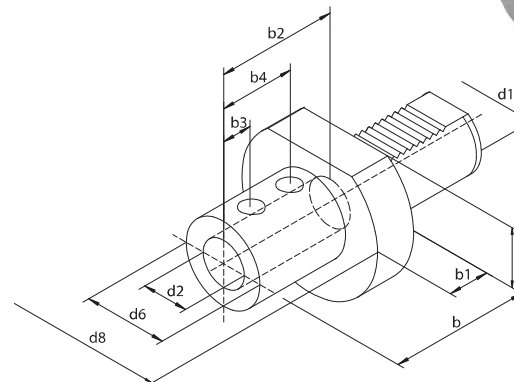
Artikel Nr.	Typ	DIN 69880	d1	d2	d6	d8	b	b1	b2	b3	b4	h
Code No.	Type											
341254021100	1254-20-16	-	20	16	36	50	67	18	54	15	35	-
341254020900	1254-20-20	E1-20x20	20	20	40	50	67	18	54	15	35	-
341254022400	1254-20-25	E1-20x25	20	25	45	50	71	18	59	17	40	-
341254031300	1254-30-16	-	30	16	36	68	67	22	54	15	35	28,0
341254030000	1254-30-20	E1-30x20	30	20	40	68	67	22	54	15	35	28,0
341254032600	1254-30-25	E1-30x25	30	25	45	68	71	22	59	17	40	28,0
341254034100	1254-30-32	E1-30x32	30	32	52	68	75	22	63	17	44	28,0
341254035400	1254-30-40	-	30	40	60	68	90	22	73	22	50	28,0
341254037000	1254-40-10	-	40	10	35	83	67	22	41	20	-	32,5
341254039500	1254-40-16	-	40	16	36	83	67	22	54	15	35	32,5
341254040200	1254-40-20	E1-40x20	40	20	40	83	67	22	54	15	35	32,5
341254042800	1254-40-25	E1-40x25	40	25	45	83	75	22	59	17	40	32,5
341254044300	1254-40-32	E1-40x32	40	32	52	83	75	22	63	17	44	32,5
341254046900	1254-40-40	E1-40x40	40	40	60	83	90	22	73	22	50	32,5
341254048400	1254-50-12	-	50	12	40	98	145	30	54	15	35	35,0
341254049700	1254-50-16	-	50	16	40	98	145	30	54	15	35	35,0
341254050400	1254-50-20	E1-50x20	50	20	40	98	67	30	54	15	35	35,0
341254052000	1254-50-25	E1-50x25	50	25	45	98	80	30	59	17	40	35,0
341254054500	1254-50-32	E1-50x32	50	32	52	98	80	30	63	17	44	35,0
341254056000	1254-50-40	E1-50x40	50	40	60	98	90	30	73	22	50	35,0
341254058600	1254-50-50	E1-50x50	50	50	70	98	100	30	83	24	60	35,0



**1254**

- Werkzeughalter für Werkzeuge mit zylindrischem Schaft
- internes Kühlmittel
- Toolholder for tools with cylindrical shank
- Internal coolant

**1258**

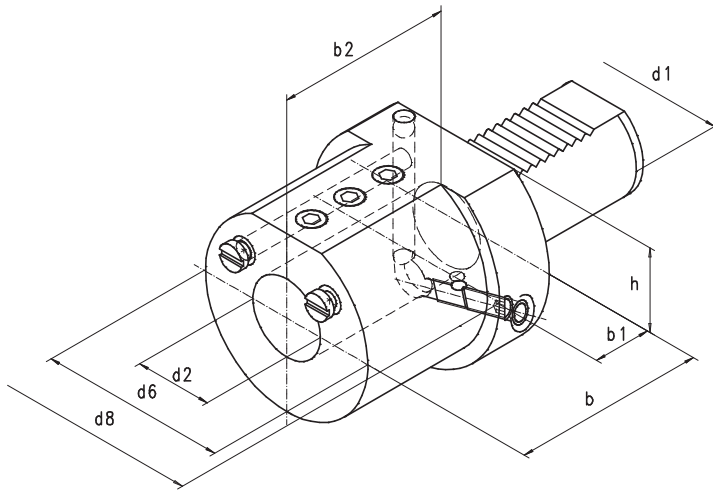

- Werkzeughalter für Werkzeuge mit zylindrischem Schaft
- Interne oder externe Kühlmittelzufuhr
- Toolholder for tools with cylindrical shank
- Internal or external coolant



Artikel Nr. Code No.	Typ Type	DIN 69880	d1	d2	d6	d8	b	b1	b2	h
341258231800	1258-16-8	E2-16 x 8	16	8	32	40	44	14	34	18,0
341258233300	1258-16-10	E2-16 x 10	16	10	32	40	44	14	34	18,0
341258235900	1258-16-12	E2-16 x 12	16	12	40	40	44	14	34	18,0
341258237400	1258-16-16	E2-16 x 16	16	16	40	40	44	14	34	18,0
341258331900	1258-20-8	E2-20 x 8	20	8	40	50	50	18	41	-
341258333400	1258-20-10	E2-20 x 10	20	10	40	50	50	18	41	-
341258335000	1258-20-12	E2-20 x 12	20	12	40	50	50	18	41	-
341258337500	1258-20-16	E2-20 x 16	20	16	40	50	50	18	41	-
341258339000	1258-20-20	E2-20 x 20	20	20	50	50	50	18	41	-
341258341000	1258-20-25	E2-20 x 25	20	25	50	50	60	18	51	-
341258431000	1258-30-8	E2-30 x 8	30	8	55	68	60	22	51	28,0
341258433500	1258-30-10	E2-30 x 10	30	10	55	68	60	22	51	28,0
341258435000	1258-30-12	E2-30 x 12	30	12	55	68	60	22	51	28,0
341258437600	1258-30-16	E2-30 x 16	30	16	55	68	60	22	51	28,0
341258439100	1258-30-20	E2-30 x 20	30	20	55	68	60	22	51	28,0
341258440900	1258-30-25	E2-30 x 25	30	25	55	68	60	22	51	28,0
341258441100	1258-30-30	-	30	30	68	68	75	22	51	28,0
341258443700	1258-30-32	E2-30 x 32	30	32	68	68	75	22	61	28,0
341258531000	1258-40-8	-	40	8	50	83	75	22	61	32,5
341258533600	1258-40-10	-	40	10	50	83	75	22	61	32,5
341258535100	1258-40-12	E2-40 x 12	40	12	50	83	75	22	61	32,5
341258537700	1258-40-16	E2-40 x 16	40	16	55	83	75	22	61	32,5
341258539200	1258-40-20	E2-40 x 20	40	20	55	83	75	22	61	32,5
341258541200	1258-40-25	E2-40 x 25	40	25	60	83	75	22	61	32,5
341258543800	1258-40-30	-	40	30	72	83	75	22	61	32,5
341258545300	1258-40-32	E2-40 x 32	40	32	72	83	75	22	61	32,5
341258547900	1258-40-40	E2-40 x 40	40	40	83	83	90	22	76	32,5
341258633700	1258-50-10	-	50	10	50	98	75	30	62	35,0
341258635200	1258-50-12	-	50	12	56	98	90	30	76	35,0
341258637800	1258-50-16	E2-50 x 16	50	16	56	98	90	30	76	35,0
341258639300	1258-50-20	E2-50 x 20	50	20	56	98	90	30	76	35,0
341258641300	1258-50-25	E2-50 x 25	50	25	65	98	90	30	76	35,0
341258643900	1258-50-30	-	50	30	68	98	90	30	76	35,0
341258645400	1258-50-32	E2-50 x 32	50	32	68	98	90	30	76	35,0
341258647000	1258-50-40	E2-50 x 40	50	40	80	98	90	30	76	35,0
341258649500	1258-50-50	E2-50 x 50	50	50	90	98	100	30	86	35,0

**1230**



- Werkzeughalter für Bohrstangen
- Toolholder for boring bars

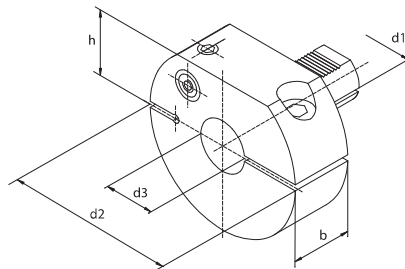

Artikel Nr. Code No.	Typ Type	d1	d2	d3	b	h
341230010000	1230-30-12	30	68	12	30	28,0
341230020100	1230-30-16	30	68	16	30	28,0
341230030300	1230-30-20	30	68	20	30	28,0
341230040500	1230-40-12	40	83	12	30	32,5
341230050700	1230-40-16	40	83	16	30	32,5
341230060900	1230-40-20	40	83	20	30	32,5
341230070000	1230-40-25	40	83	25	30	32,5
341230110000	1230-50-16	50	98	16	30	35,0
341230120200	1230-50-20	50	98	20	30	35,0
341230130400	1230-50-25	50	98	25	30	35,0
341230140600	1230-50-32	50	98	32	30	35,0

Artikel Nr. Code No.	Typ Type	DIN 69880	d1	a	h	b
341201000400	1201-16	A1-16 x 44	16	78	44	44
341201010600	1201-20	A1-20 x 65	20	100	60	65
341201020800	1201-30	A1-30 x 85	30	130	76	85
341201030000	1201-40	A1-40 x 100	40	151	96	100
341201040100	1201-50	A1-50 x 125	50	160	120	125

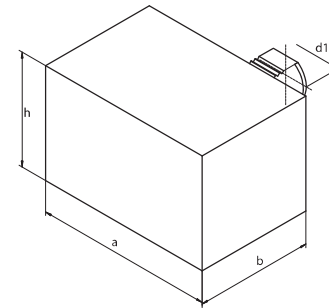
**1201**

- 1
- 2
- 3
- 4
- 5
- 6

Artikel Nr. Code No.	Typ Type	DIN 69880	d1	d2	b
341203000000	1203-16	A2-16 x 60	16	40	60
341203010200	1203-20	A2-20 x 70	20	50	70
341203020400	1203-30	A2-30 x 100	30	68	100
341203030600	1203-30L	A2-30 x 240	30	68	240
341203040800	1203-40	A2-40 x 120	40	83	120
341203050000	1203-40L	A2-40 x 320	40	83	320
341203060100	1203-50	A2-50 x 135	50	98	135
341203070300	1203-50L	A2-50 x 400	50	98	400

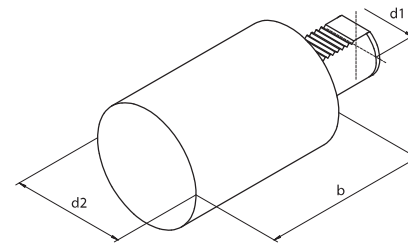
**1203**



- 1201
- 1203

1  
2  
3  
4  
5  
6

**1225**

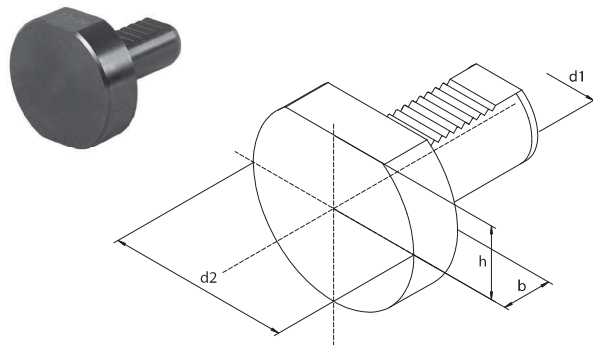

- Verschlussstopfen
- Blanking plug (steel)



Artikel Nr. Code No.	Typ Type	DIN 69880	d1	d2	b	h
341225000100	1225-16	Z2-16	16	40	13	18,0
341225001400	1225-20	Z2-20	20	50	16	23,0
341225010300	1225-25	Z2-25	25	58	16	25,0
341225020500	1225-30	Z2-30	30	68	16	28,0
341225030700	1225-40	Z2-40	40	83	20	32,5
341225040900	1225-50	Z2-50	50	98	20	35,0

**1227**



- Klemmringe für Reduzierhülse Typ 1228
- Clamping ring used with the sleeves type 1228

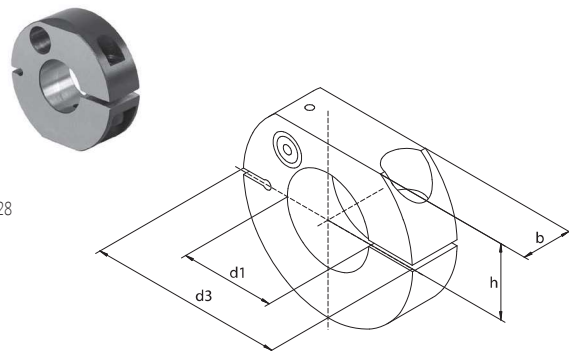

Artikel Nr. Code No.	Typ Type	DIN 69880	d1	d3	b	h
341227010000	1227-20	Z1-20	20	50	16	23,0
341227020100	1227-25	Z1-25	25	58	16	25,0
341227030300	1227-30	Z1-30	30	68	22	28,0
341227040500	1227-40	Z1-40	40	83	22	32,5
341227050700	1227-50	Z1-50	50	98	30	35,0

**1228**

- Reduzierhülse
- Reducing sleeve with morse taper

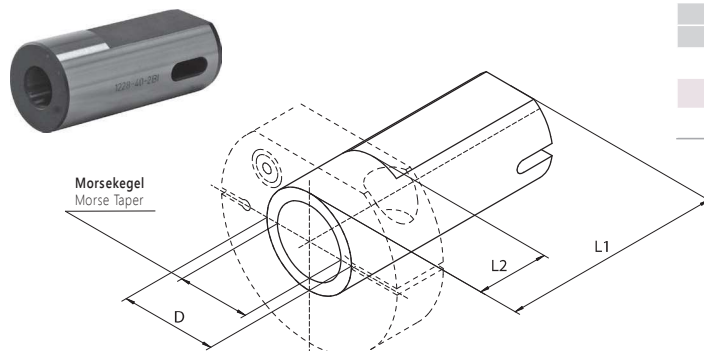

Artikel Nr. Code No.	Typ Type	D	Morsekegel Morse Taper	L1	L2
341228030100	1228-40-2BI	40	2	95	30
341228031400	1228-40-3BI	40	3	95	30
341228032700	1228-40-4BI	40	4	118	55

1225  
1227  
1228

Artikel Nr. Code No.	Für Typ For Type	Ausführung Version	a	b	h
398342090500	1114-16P	I	10,5	36	4,5
398342090500	1114-16P-L	I	10,5	36	4,5
398342090500	1115-16P	I	10,5	36	4,5
398342090500	1115-16P-L	I	10,5	36	4,5
398342080300	1114-20P	I	13,5	47	5,0
398342080300	1114-20P-L	I	13,5	47	5,0
398342070100	1114-30P	I	17,5	59	8,0
398342070100	1114-30P-L	I	17,5	59	8,0
398342070100	1114-30L	I	17,5	59	8,0
398342070100	1114-30L-L	I	17,5	59	8,0
398342070100	1133-30P	I	17,5	59	8,0
398342070100	1133-30L	I	17,5	59	8,0
398342070100	1115-30P	I	17,5	59	8,0
398342070100	1115-30P-L	I	17,5	59	8,0
398342070100	1115-30L	I	17,5	59	8,0
398342070100	1115-30L-L	I	17,5	59	8,0
398342070100	1134-30P	I	17,5	59	8,0
398342070100	1134-30L	I	17,5	59	8,0
398342120300	1124-30P	II	17,5	89	8,0
398342120300	1124-30P-L	II	17,5	89	8,0
398342120300	1125-30L	II	17,5	89	8,0
398342120300	1124-30L-L	II	17,5	89	8,0
398342120300	1125-30P	II	17,5	89	8,0
398342120300	1125-30P-L	II	17,5	89	8,0
398342120300	1124-30L	II	17,5	89	8,0
398342120300	1125-30L-L	II	17,5	89	8,0
398342040600	1133-40P	I	21,2	72	8,0
398342040600	1134-40P	I	21,2	72	8,0
398342030400	1114-40P	I	21,5	72	8,0
398342030400	1114-40L	I	21,5	72	8,0
398342030400	1133-40L	I	21,5	72	8,0
398342030400	1115-40P	I	21,5	72	8,0
398342030400	1115-40L	I	21,5	72	8,0
398342030400	1134-40L	I	21,5	72	8,0
398342110100	1124-40P	II	21,5	105	8,0
398342110100	1124-40L	II	21,5	105	8,0
398342110100	1125-40P	II	21,5	105	8,0
398342110100	1125-40L	II	21,5	105	8,0
398342010000	1133-50P	I	23,7	83	8,0
398342010000	1134-50P	I	23,7	83	8,0
398342020200	1133-50L	I	24,2	83	8,0
398342020200	1134-50L	I	24,2	83	8,0
398342000900	1114-50P	I	24,5	83	8,0
398342000900	1114-50L	I	24,5	83	8,0
398342000900	1115-50P	I	24,5	83	8,0
398342000900	1115-50L	I	24,5	83	8,0
398342100000	1124-50P	II	24,5	113	8,0
398342100000	1124-50L	II	24,5	113	8,0
398342100000	1125-50P	II	24,5	113	8,0
398342100000	1125-50L	II	24,5	113	8,0

**KLEMMPLATTE**  
PLATE

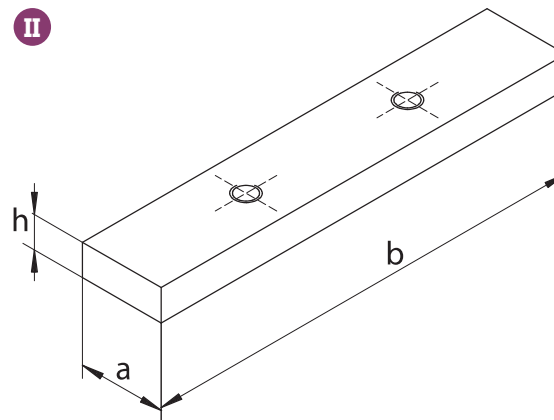
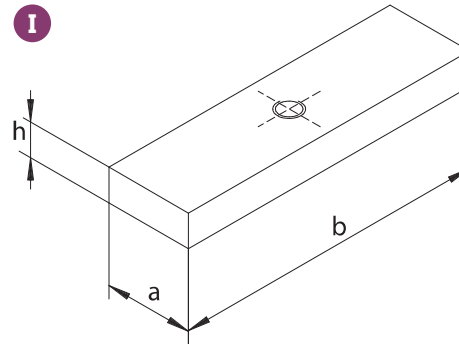

- 1
- 2
- 3
- 4
- 5
- 6

1

2

3

4

5

6

**UNTERLEGPLATTE**  
PLATE

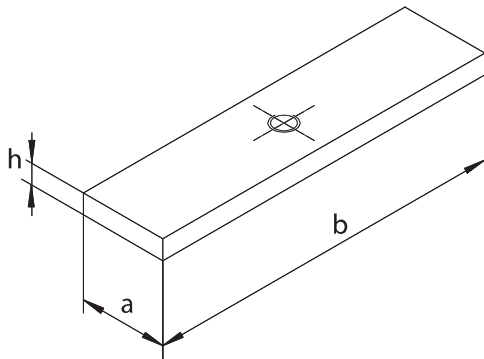

Artikel Nr. Code No.	Für Typ For Type	a	b	h
398341030600	1114-16P	10,5	41	2
398341030600	1114-16P-L	10,5	41	2
398341030600	1115-16P	10,5	41	2
398341030600	1115-16P-L	10,5	41	2
398341020400	1114-20P	13,5	54	4
398341020400	1114-20P-L	13,5	54	4
398341010200	1124-30P	17,5	99	4
398341010200	1124-30P-L	17,5	99	4
398341010200	1125-30L	17,5	99	4
398341010200	1124-30L-L	17,5	99	4
398341010200	1125-30P	17,5	99	4
398341010200	1125-30P-L	17,5	99	4
398341010200	1124-30L	17,5	99	4
398341010200	1125-30L-L	17,5	99	4
398341000000	1114-30P	17,5	69	4
398341000000	1114-30P-L	17,5	69	4
398341000000	1114-30L	17,5	69	4
398341000000	1114-30L-L	17,5	69	4
398341000000	1133-30P	17,5	69	4
398341000000	1133-30L	17,5	69	4
398341000000	1115-30P	17,5	69	4
398341000000	1115-30P-L	17,5	69	4
398341000000	1115-30L	17,5	69	4
398341000000	1115-30L-L	17,5	69	4
398341000000	1134-30P	17,5	69	4
398341000000	1134-30L	17,5	69	4

Artikel Nr. Code No.	Für Typ For Type	A	B	H
398340070500	1124-40P	21,5	117	5
398340070500	1124-40L	21,5	117	5
398340070500	1125-40P	21,5	117	5
398340070500	1125-40L	21,5	117	5
398340060300	1133-40P	21,2	84	5
398340060300	1134-40P	21,2	84	5
398340050100	1114-40P	21,5	84	5
398340050100	1114-40L	21,5	84	5
398340050100	1133-40L	21,5	84	5
398340050100	1115-40P	21,5	84	5
398340050100	1115-40L	21,5	84	5
398340050100	1134-40L	21,5	84	5
398340040000	1133-50L	24,2	99	7
398340040000	1134-50L	24,2	99	7
398340030800	1133-50P	23,7	99	7
398340030800	1134-50P	23,7	99	7
398340020600	1124-50P	24,5	129	7
398340020600	1124-50L	24,5	129	7
398340020600	1125-50P	24,5	129	7
398340020600	1125-50L	24,5	129	7
398340010400	1114-50P	24,5	99	7
398340010400	1124-50L	24,5	99	7
398340010400	1115-50P	24,5	99	7
398340010400	1125-50L	24,5	99	7